

 **PH68**

Encoder with measurement range
up to 255 revolutions

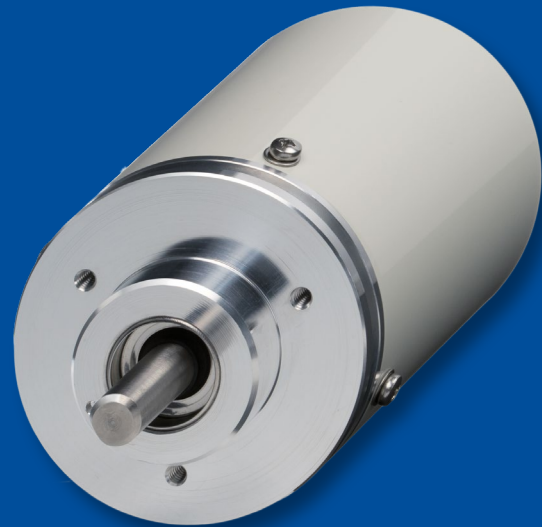

- Housing diameter 68 mm
- Protection class up to IP67/IP69
- True-absolute measurement principle
- Wear and maintenance free
- Redundant version available

Product versions



Analog output



Analog output, programmable / tare
function



Analog output, redundant



Digital output CANopen



Digital output CANopen, redundant



PH68 - Magnetic Multiturn Encoder
Version with analog output

Specifications

		Order options	
Shaft	Shaft 10 mm	1	V61
Measurement range	up to 255 x 360° (255 revolutions) 1 revolution, 2 revolutions ... up to 255 revolutions	2	1T 2T ... 255T
Output	Voltage 0.5 ... 10 V Voltage 0.5 ... 4.5 V Voltage 0.5 ... 4.5 V Current 4 ... 20 mA, 3 wire	3	U2 U6 U8 I1
Resolution	Up to 16 bit		
Repeatability	0.1°		
Linearity	±(2° + 0.015% f.s.)		
Housing material	Aluminum (housing), stainless steel (shaft)		
Mounting	Clamps or screws		
Protection class	IP67 shaft IP67/69 housing (with IP69 compatible connector)		
Signal characteristics	Signal increasing CW Signal increasing CCW	4	CW CCW
Connection	Connector M12 axial, 5 pin	5	M12A5
Revolutions per minute (mechanical)	10,000 r.p.m.		
Allowable shaft load	70 N radial, 50 N axial		
Life cycle of bearings	1.1 x 10 ¹⁰ rev. (3000 h per 6000 r.p.m)		
Shock	DIN EN 60068-2-27:2010, 100 g/11 ms, 100 shocks		
Vibration	EN 60068-2-6:2008, 20 g 10 Hz-2 kHz, 10 cycles		
Temperature range	-40 ... +85°C		
Weight	approx. 450 g		
EMC	DIN EN 61326-1:2013		

Order code

PH68	-	1	-	2	-	3	-	4	-	5
------	---	----------	---	----------	---	----------	---	----------	---	----------

Order example: PH68 – V61 – 255T – I1 – CW – M12A5



PH68 - Magnetic Multiturn Encoder
Version with analog output, programmable / tare function

Specifications

		Order options	
Shaft	Shaft 10 mm	1	V61
Measurement range	up to 255 x 360° (255 revolutions) 1 revolution, 2 revolutions ... up to 255 revolutions	2	1T 2T ... 255T
Output	Voltage 0.5 ... 10 V, programmable Voltage 0.5 ... 4.5 V, programmable Voltage 0.5 ... 4.5 V, programmable Current 4 ... 20 mA, 3 wire, programmable Voltage 0.5 ... 10 V, tare function Voltage 0.5 ... 4.5 V, tare function Voltage 0.5 ... 4.5 V, tare function Current 4 ... 20 mA, 3 wire, tare function	3	U2/PMU U6/PMU U8/PMU I1/PMU U2/PMZ U6/PMZ U8/PMZ I1/PMZ
Resolution	Up to 16 bit		
Repeatability	0.1°		
Linearity	±(2°+ 0.015% f.s.)		
Housing material	Aluminum (housing), stainless steel (shaft)		
Mounting	Clamps or screws		
Protection class	IP67 shaft IP67/69 housing (with IP69 compatible connector)		
Signal characteristics	Signal increasing CW Signal increasing CCW	4	CW CCW
Connection	Connector M12 axial, 5 pin	5	M12A5
Revolutions per minute (mechanical)	10,000 r.p.m.		
Allowable shaft load	70 N radial, 50 N axial		
Life cycle of bearings	1.1 x 10 ¹⁰ rev. (3000 h per 6000 r.p.m)		
Shock	DIN EN 60068-2-27:2010, 100 g/11 ms, 100 shocks		
Vibration	EN 60068-2-6:2008, 20 g 10 Hz-2 kHz, 10 cycles		
Temperature range	-40 ... +85°C		
Weight	approx. 450 g		
EMC	DIN EN 61326-1:2013		

Order code

PH68	-	1	-	2	-	3	-	4	-	5
------	---	----------	---	----------	---	----------	---	----------	---	----------

Order example: PH68 – V61 – 255T – U2/PMU – CW – M12A5



PH68 - Magnetic Multiturn Encoder
Version with analog output, redundant

Specifications

		Order options	
Shaft	Shaft 10 mm	1	V61
Measurement range	up to 255 x 360° (255 revolutions) 1 revolution, 2 revolutions ... up to 255 revolutions	2	1T 2T ... 255T
Output	Voltage 0.5 ... 10 V, two channels, redundant Voltage 0.5 ... 4.5 V two channels, redundant Voltage 0.5 ... 4.5 V two channels, redundant Current 4 ... 20 mA, 3 wire, redundant	3	U2R U6R U8R I1R
Resolution	Up to 16 bit		
Repeatability	0.1°		
Linearity	±(2° + 0.015% f.s.)		
Housing material	Aluminum (housing), stainless steel (shaft)		
Mounting	Clamps or screws		
Protection class	IP67 shaft IP67/69 housing (with IP69 compatible connector)		
Signal characteristics	Signal 1 increasing CW / signal 2 increasing CW Signal 1 increasing CCW / signal 2 increasing CCW Signal 1 increasing CCW / signal 2 increasing CCW	4	CW/CW CW/CCW CCW/CCW
Connection	2x Connector M12 axial, 5 pin	5	2M12A5
Revolutions per minute (mechanical)	10,000 r.p.m.		
Allowable shaft load	70 N radial, 50 N axial		
Life cycle of bearings	1.1 x 10 ¹⁰ rev. (3000 h per 6000 r.p.m)		
Shock	DIN EN 60068-2-27:2010, 100 g/11 ms, 100 shocks		
Vibration	EN 60068-2-6:2008, 20 g 10 Hz-2 kHz, 10 cycles		
Temperature range	-40 ... +85°C		
Weight	approx. 450 g		
EMC	DIN EN 61326-1:2013		

Order code



Order example: PH68 – V61 – 255T – I1R – CW – 2M12A5



PH68 - Magnetic Multiturn Encoder
Version with digital output CANopen

Specifications

			Order options
Shaft	Shaft 10 mm	1	V61
Measurement range	up to 255 x 360° (255 revolutions) 1 revolution, 2 revolutions ... up to 255 revolutions	2	1T 2T ... 255T
Output	CANopen (CiA 301-V4.02/406-V3.2) CANopenR redundant CAN SAE J1939 CAN SAE J1939R redundant	3	MCANOP MCANOPR MCANJ1939 MCANJ1939R
Resolution	14 bit per revolution		
Repeatability	0.1°		
Linearity	±1°		
Housing material	Aluminum (housing), stainless steel (shaft)		
Mounting	Clamps or screws		
Protection class	IP67 shaft IP67/69 housing (with IP69 compatible connector)		
Connection	Connector M12 axial, 5 pin	4	M12A5/CAN
Revolutions per minute (mechanical)	10,000 r.p.m.		
Allowable shaft load	70 N radial, 50 N axial		
Life cycle of bearings	1.1 x 10 ¹⁰ rev. (3000 h per 6000 r.p.m)		
Shock	DIN EN 60068-2-27:2010, 100 g/11 ms, 100 shocks		
Vibration	EN 60068-2-6:2008, 20 g 10 Hz-2 kHz, 10 cycles		
Temperature range	-40 ... +85°C		
Weight	approx. 450 g		
EMC	DIN EN 61326-1:2013		

Order code

PH68	-	1	-	2	-	3	-	4
------	---	---	---	---	---	---	---	---

Order example: PH68 – V61 – 255T – MCANOP – M12A5/CAN

Dimensions

PH68, connector M12 axial

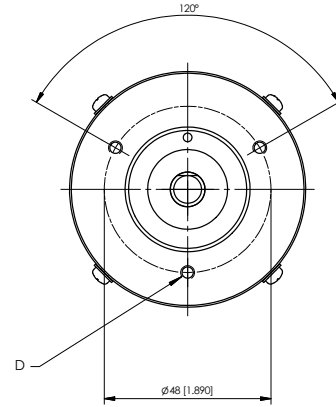
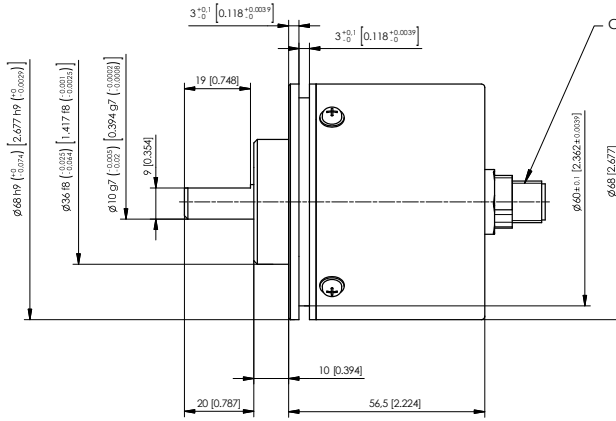

C – Connector M12
D – M4 – 7 [0.276] deep

Dimensions in mm [inch].
Dimensions informative only.
For guaranteed dimensions consult factory.

PH68R, connector M12 axial (2x)

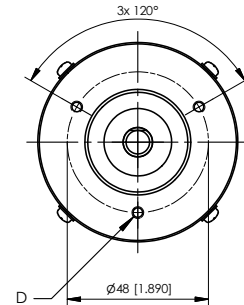
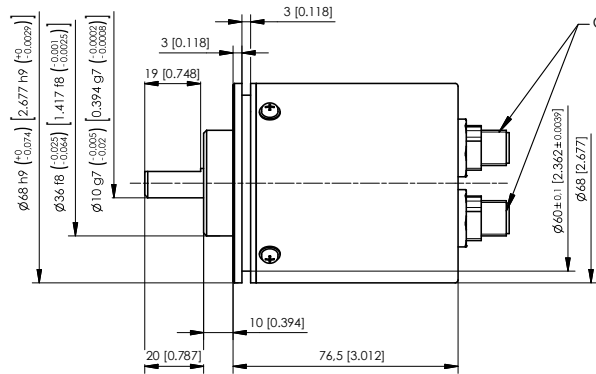
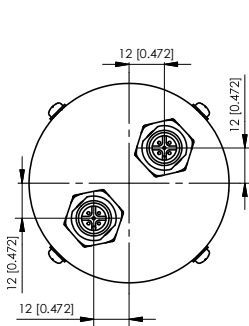



C – Connector M12
D – M4 – 7 [0.276] deep

Dimensions in mm [inch].
Dimensions informative only.
For guaranteed dimensions consult factory.

Output specification

Analog output

U2 Voltage output 0.5 ... 10 V 	Excitation voltage	8 ... 36 V DC
	Excitation current	20 mA typical at 24 V DC 38 mA typical at 12 V DC max. 50 mA
	Output voltage	0.5 ... 10 V DC
	Output current	2 mA max.
	Measuring rate	1 kHz standard
	Stability (temperature)	$\pm 50 \times 10^{-6}$ / °C f.s. (typical)
	Protection	Reverse polarity, short circuit
	Operating temperature	See specification of the respective sensor
	EMC	DIN EN 61326-1:2013

U6 Voltage output 0.5 ... 4.5 V 	Excitation voltage	5 V DC $\pm 5\%$
	Excitation current	typical 140 mA max.
	Output voltage	0.5 ... 4.5 V DC
	Output current	2 mA max.
	Measuring rate	1 kHz standard
	Stability (temperature)	$\pm 50 \times 10^{-6}$ / °C f.s. (typical)
	Protection	Reverse polarity, short circuit
	Operating temperature	See specification of the respective sensor
	EMC	DIN EN 61326-1:2013

U8 Voltage output 0.5 ... 4.5 V 	Excitation voltage	8 ... 36 V DC
	Excitation current	17 mA typical at 24 V DC 32 mA typical at 12 V DC 50 mA max.
	Output voltage	0.5 ... 4.5 V DC
	Output current	2 mA max.
	Measuring rate	1 kHz standard
	Stability (temperature)	$\pm 50 \times 10^{-6}$ / °C f.s. (typical)
	Protection	Reverse polarity, short circuit
	Operating temperature	See specification of the respective sensor
	EMC	DIN EN 61326-1:2013

I1 Current output 4 ... 20 mA, 3 wires 	Excitation voltage	8 ... 36 V DC
	Excitation current	typical 36 mA at 24 V DC typical 70 mA at 12 V DC 120 mA max.
	Load R _L	500 Ω max.
	Output current	4 ... 20 mA
	Measuring rate	1 kHz standard
	Stability (temperature)	±50 x 10 ⁻⁶ / °C f.s. (typical)
	Protection	Reverse polarity, short circuit
	Operating temperature	See specification of the respective sensor
	EMC	DIN EN 61326-1:2013

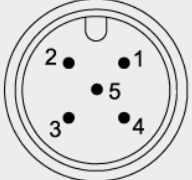
Signal wiring	Output signals	Connector pin no.	Cable color
Connector M12, 5 pin  View to the sensor connector	Excitation +	1	brown
	Signal	2	white
	GND	3	blue
	Do not connect!	4	black
	Do not connect!	5	(grey)

Analog output, programmable / tare function

U2/PMU programmable U2/PMZ tare function Voltage output 0.5 ... 10 V 	Excitation voltage	8 ... 36 V DC
	Excitation current	20 mA typical at 24 V DC 38 mA typical at 12 V DC max. 50 mA
	Output voltage	0,5 ... 10 V DC
	Output current	2 mA max.
	Measuring rate	1 kHz standard
	Stability (temperature)	$\pm 50 \times 10^{-6}$ / °C f.s. (typical)
	Protection	Reverse polarity, short circuit
	Operating temperature	See specification of the respective sensor
	EMC	DIN EN 61326-1:2013

U6/PMU programmable U6/PMZ tare function Voltage output 0.5 ... 4.5 V 	Excitation voltage	5 V DC $\pm 5\%$
	Excitation current	typical 140 mA
	Output voltage	0.5 ... 4.5 V DC
	Output current	2 mA max.
	Measuring rate	1 kHz standard
	Stability (temperature)	$\pm 50 \times 10^{-6}$ / °C f.s. (typical)
	Protection	Reverse polarity, short circuit
	Operating temperature	See specification of the respective sensor
	EMC	DIN EN 61326-1:2013

U8/PMU programmable U8/PMZ tare function Voltage output 0.5 ... 4.5 V 	Excitation voltage	8 ... 36 V DC
	Excitation current	17 mA typical at 24 V DC 32 mA typical at 12 V DC max. 50 mA
	Output voltage	0.5 ... 4.5 V DC
	Output current	2 mA max.
	Measuring rate	1 kHz standard
	Stability (temperature)	$\pm 50 \times 10^{-6}$ / °C f.s. (typical)
	Protection	Reverse polarity, short circuit
	Operating temperature	See specification of the respective sensor
	EMC	DIN EN 61326-1:2013

I1/PMU programmable I1/PMZ tare function Current output 4 ... 20 mA, 3 wire 	Excitation voltage	8 ... 36 V DC
	Excitation current	typical 36 mA at 24 V DC typical 70 mA at 12 V DC max. 120 mA
	Load R _L	500 Ω max.
	Output current	4 ... 20 mA
	Measuring rate	1 kHz standard
	Stability (temperature)	±50 x 10 ⁻⁶ / °C f.s. (typical)
	Protection	Reverse polarity, short circuit
	Operating temperature	See specification of the respective sensor
	EMC	DIN EN 61326-1:2013

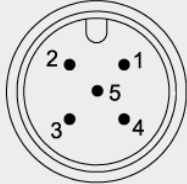
Signal wiring	Output signals	Connector pin no.	Cable color
Connector M12, 5 pin  View to the sensor connector	Excitation +	1	brown
	Signal	2	white
	GND	3	blue
	Do not connect!	4	black
	SPAN/ZERO	5	grey

Output .../PMU

Programming of the start and end value by the customer (programmable)

Teach-In of start and end value for the analog outputs U2/PMU, U8/PMU, I1/PMU is provided by a binary signal SPAN/ZERO. At the start position connect signal SPAN/ZERO for a period of 2 ... 3 seconds to GND via push button. At the end position connect signal SPAN/ZERO for a period of 5 ... 6 seconds to GND via a push button. The scaling range will be stored non-volatile.

To reset the sensor to factory default ZERO/END must be connected to ground while powering up the sensor for 2 ... 3 seconds.

Output .../PMZ

Programming of the zero point by the customer (tare function)

Teach-In of the zero point for the analog outputs U2/PMZ, U6/PMZ, U8/PMZ and I1/PMZ is provided by a binary signal SPAN/ZERO. At the start position connect signal SPAN/ZERO for a period of 2 ... 3 seconds to GND via push button. The sensitivity of the output signal remains unchanged. The programmed position will be stored non-volatile. To reset the sensor to the factory values the button must be pushed for a period of 2 ... 3 seconds when the sensor is switched on.

Analog output, redundant

U2R Voltage output 0.5 ... 10 V 	Excitation voltage	8 ... 36 V DC
	Excitation current	20 mA typical at 24 V DC 38 mA typical at 12 V DC max. 50 mA per channel
	Output voltage	0.5 ... 10 V DC
	Output current	2 mA max.
	Measuring rate	1 kHz standard
	Stability (temperature)	$\pm 50 \times 10^{-6}$ / °C f.s. (typical)
	Protection	Reverse polarity, short circuit
	Operating temperature	See specification of the respective sensor
	EMC	DIN EN 61326-1:2013

U6R Voltage output 0.5 ... 4.5 V 	Excitation voltage	5 V DC $\pm 5\%$
	Excitation current	typical 140 mA per channel
	Output voltage	0.5 ... 4.5 V DC
	Output current	2 mA max.
	Measuring rate	1 kHz standard
	Stability (temperature)	$\pm 50 \times 10^{-6}$ / °C f.s. (typical)
	Protection	Reverse polarity, short circuit
	Operating temperature	See specification of the respective sensor
	EMC	DIN EN 61326-1:2013

U8R Voltage output 0.5 ... 4.5 V 	Excitation voltage	8 ... 36 V DC
	Excitation current	17 mA typical at 24 V DC 32 mA typical at 12 V DC max. 50 mA per channel
	Output voltage	0.5 ... 4.5 V DC
	Output current	2 mA max.
	Measuring rate	1 kHz standard
	Stability (temperature)	$\pm 50 \times 10^{-6}$ / °C f.s. (typical)
	Protection	Reverse polarity, short circuit
	Operating temperature	See specification of the respective sensor
	EMC	DIN EN 61326-1:2013

I1R Current output 4 ... 20 mA, 3 wires 	Excitation voltage	8 ... 36 V DC
	Excitation current	36 mA typical at 24 V DC 76 mA typical at 12 V DC max. 120 mA per channel
	Load R _L	500 Ω max.
	Output current	4 ... 20 mA
	Measuring rate	1 kHz standard
	Stability (temperature)	±50 x 10 ⁻⁶ / °C f.s. (typical)
	Protection	Reverse polarity, short circuit
	Operating temperature	See specification of the respective sensor
	EMC	DIN EN 61326-1:2013

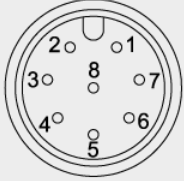
Signal wiring	Channel	Output signals	Connector pin no.	Cable color
Connector M12, 8 pin  View to the sensor connector	1	Excitation +	1	white
		Signal	2	brown
		GND	3	green
		Do not connect!	4	yellow
	2	Excitation +	5	grey
		Signal	6	pink
		GND	7	blue
		Do not connect!	8	red

Digital output

CANOP CANopen 	CAN Specification	ISO 11898, Basic and Full CAN 2.0 B
	Communication profile	CANopen CiA 301 V 4.02, Slave
	Device profile	Encoder CiA 406 V 3.2
	Configuration services	Layer Setting Service (LSS), CiA Draft Standard 305 (transmission rate, node id)
	Error Control	Node Guarding, Heartbeat, Emergency Message
	Node ID	Default: 127; programmable via LSS or SDO
	PDO	3 TxPDO, 0 RxPDO, static mapping
	PDO Modes	Event-/Time triggered, Remote-request, Sync cyclic/acyclic
	SDO	1 server, 0 Client
	CAM	8 cams
	Certified	Yes
	Transmission rates	50 kBaud to 1 MBaud, default: 125 kBaud; programmable via LSS or SDO
	Bus connection	M12 connector, 5 pin
	Integrated bus terminating resistor	Adjustable by the customer
	Bus, galvanic isolated	No

Specifications	Excitation voltage	8 ... 36 V DC
	Excitation current	20 mA typical at 24 V DC 40 mA typical at 12 V DC, 80 mA max.
	Resolution	0.05° max.
	Stability (temperature)	±50 x 10 ⁻⁶ /°C f.s. (typical)
	Repeatability	1 LSB
	Operating temperature	See specification of the respective sensor
	Protection	Reverse polarity, short circuit
	Dielectric strength	1 kV (V AC, 50 Hz, 1 min.)
	EMC	DIN EN 61326-1:2013

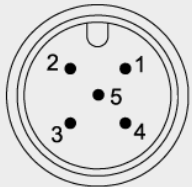
Signal wiring	Output signals	Connector pin no.	Cable color
Connector M12, 5 pin 	Shield	1	brown
	Excitation +	2	white
	GND	3	blue
	CAN-H	4	black
	CAN-L	5	grey

View to the sensor connector

MCANJ1939 SAE J1939 	CAN Specification	ISO 11898, Basic and Full CAN 2.0 B
	Transceiver	24V-compliant, not isolated
	Communication profile	SAE J1939
	Baud Rate	250 kbit/s
	Internal termination resistor	120 Ω adjustable by the customer
	Address	Default 247d, configurable

NAME Fields	Arbitrary address capable	1	Yes
	Industry group	0	Global
	Vehicle system	7Fh (127d)	Non specific
	Vehicle system instance	0	
	Function	FFh (255d)	Non specific
	Function instance	0	
	ECU instance	0	
	Manufacturer	145h (325d)	Manufacturer ID
	Identity number	0nnn	Serial number 21 bit

Parameter Group Numbers (PGN)	Configuration data	PGN EF00h	Proprietary-A (PDU1 peer-to-peer)
	Process data	PGN FFnnh	Proprietary-B (PDU2 broadcast); nn Group Extension (PS) configurable

Specifications	Excitation voltage	8 ... 36 V DC
	Excitation current	20 mA typical at 24 V DC 40 mA typical at 12 V DC max. 80 mA
	Measuring rate	1 kHz (asynchronous)
	Stability (temperature)	±50 x 10 ⁻⁶ /°C f.s. (typical)
	Repeatability	1 LSB
	Operating temperature	See specification of the respective sensor
	Protection	Reverse polarity, short circuit
	Dielectric strength	1 kV (V AC, 50 Hz, 1 min.)
	EMV	EN 61326-1:2013

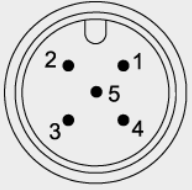
Signal wiring	Output signals	Connector pin no.	Cable color
Connector M12, 5 pin  View to the sensor connector	Shield	1	brown
	Excitation +	2	white
	GND	3	blue
	CAN-H	4	black
	CAN-L	5	grey

Connector cables
Connector cable M12, 4 pin
(angular coupling)

shielded connector
Suitable for 5-pin
sensor connectors

The 4-core screened cable is supplied with a mating 4-pin 90° M12 connector at one end and 4 wires at the other end. Available lengths are 2 m, 5 m and 10 m. Wire: cross sectional area 0.34 mm²
Cable diameter: 5.6 ±0.2 mm

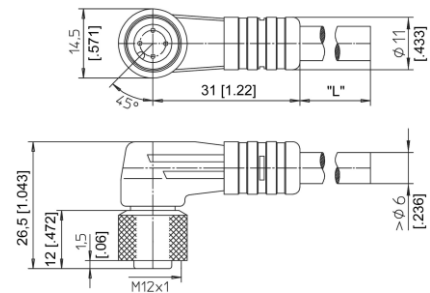

Order code

KAB - xM - M12/4F/W - LITZE

IP69: **KAB - xM - M12/4F/W/69K - LITZE**

xM = length in m

Connector cable M12, 4 pin
(straight coupling)

shielded connector
Suitable for 5-pin
sensor connectors

The 4-core screened cable is supplied with a mating 4-pin M12 connector at one end and 4 wires at the other end. Available lengths are 2 m, 5 m and 10 m. Wire: cross sectional area 0.34 mm²
Cable diameter: 5.6 ±0.2 mm

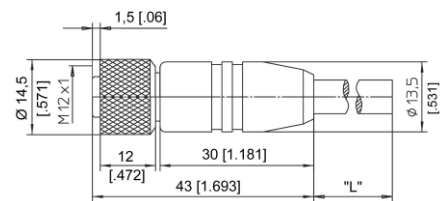

Order code

KAB - xM - M12/4F/G - LITZE

IP69: **KAB - xM - M12/4F/G/69K - LITZE**

xM = length in m

Signal wiring	Plug connection / cable color			
	M12, 4 pin	1	2	3
	brown	white	blue	black

Applicable for cable carriers

Maximum movement speed	3 m/s
Maximum acceleration	5 m/s ²
Minimum bending radius	10 x cable diameter

Connector cable M12, 5 pin (angular coupling)

shielded connector

The 5-core screened cable is supplied with a mating 5-pin 90° M12 connector at one end and 4 wires at the other end. Available lengths are 2 m, 5 m and 10 m.

Wire: cross sectional area 0.34 mm²

Cable diameter: 5.6 ±0.2 mm

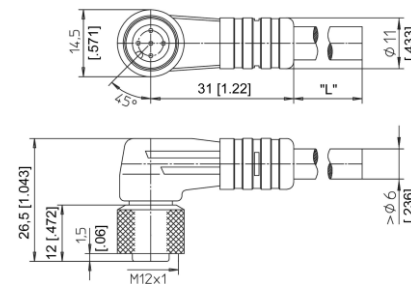

Order code

KAB - xM - M12/5F/W - LITZE

IP69: **KAB - xM - M12/5F/W/69K - LITZE**

xM = length in m

Connector cable M12, 5 pin (straight coupling)

shielded connector

The 5-core screened cable is supplied with a mating 5-pin M12 connector at one end and 4 wires at the other end. Available lengths are 2 m, 5 m and 10 m.

Wire: cross sectional area 0.34 mm²

Cable diameter: 5.6 ±0.2 mm

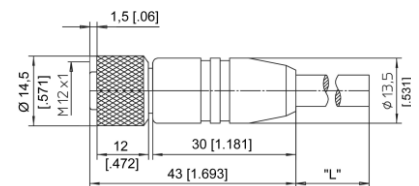

Order code

KAB - xM - M12/5F/G - LITZE

IP69: **KAB - xM - M12/5F/G/69K - LITZE**

xM = length in m

Signal wiring M12, 5 pin	Plug connection / Cable color				
	1	2	3	4	5
	brown	white	blue	black	grey

Applicable for cable carriers

Maximum movement speed	3 m/s
Maximum acceleration	5 m/s ²
Minimum bending radius	10 x cable diameter

Connector cable M12, 8 pin (angular coupling)

shielded connector

The 8-lead shielded cable is supplied with a mating 8-pin 90° M12 connector at one end and 8 wires at the other end. Available lengths are 2 m, 5 m and 10 m.
Wire: cross sectional area 0.25 mm²
Cable diameter: 6.3 ±0.2 mm

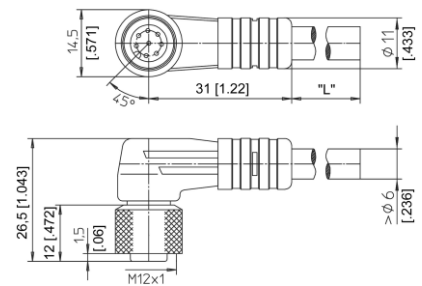

Order code

KAB - xM - M12/8F/W - LITZE

IP69: **KAB - xM - M12/8F/W/69K - LITZE**

xM = length in m

Connector cable M12, 8 pin (straight coupling)

shielded connector

The 8-lead shielded cable is supplied with a mating 8-pin M12 connector at one end and 8 wires at the other end. Available lengths are 2 m, 5 m and 10 m.
Wire: cross sectional area 0.25 mm²
Cable diameter: 6.3 ±0.2 mm

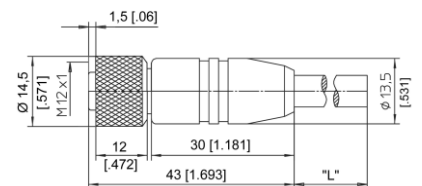

Order code

KAB - xM - M12/8F/G - LITZE

IP69: **KAB - xM - M12/8F/G/69K - LITZE**

xM = length in m

Signal wiring M12, 8 pin	Plug connection / cable color							
	1	2	3	4	5	6	7	8
	white	brown	green	yellow	grey	pink	blue	red

Applicable for cable carriers

Maximum movement speed	3 m/s
Maximum acceleration	5 m/s ²
Minimum bending radius	10 x cable diameter

Connector/bus cable M12, 5 pin CAN-Bus

The 5-lead shielded cable is supplied with a female 5 pin M12 connector at one end and a male 5 pin M12 connector at the other end.

Available lengths are 0.3 m, 2 m, 5 and 10 m.

Cable diameter: 6.7 ±0.2 mm

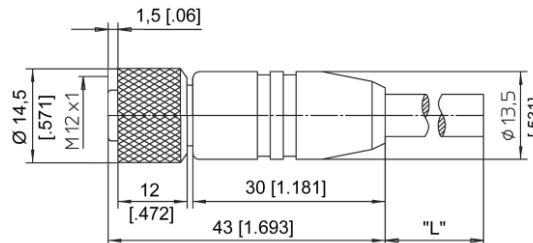

Order code

KAB - xM - M12/5F/G - M12/5M/G - CAN

IP69: **KAB - xM - M12/5F/G/69K - M12/5M/G/69K - CAN**

xM = length in m

T-connector for bus cable M12, 5 pin CAN-Bus

Order code

KAB - TCONN - M12/5M - 2M12/5F - CAN



Terminating resistor M12, 5 pin CAN-Bus

Order code

KAB - RTERM - M12/5M/G - CAN



Applicable for cable carriers

Maximum movement speed	3 m/s
Maximum acceleration	5 m/s ²
Minimum bending radius	10 x cable diameter