

Key Features

EPIC® Seal	Ceramic to metal braze. Gas filled hermetic chamber protects key components. Exceeds IP69K standard
Temperature	Tested to temperatures up to 200°C
Contacts / Form	Silver / SPST / NO
Coil	Efficient two coil design with no PWM or EMI emissions. Coil suppression built in
High Shock and Vibration	For rugged environments, off-road and tracked vehicles
Installation	Not direction sensitive
Reference	MIL-R-6106, RoHS

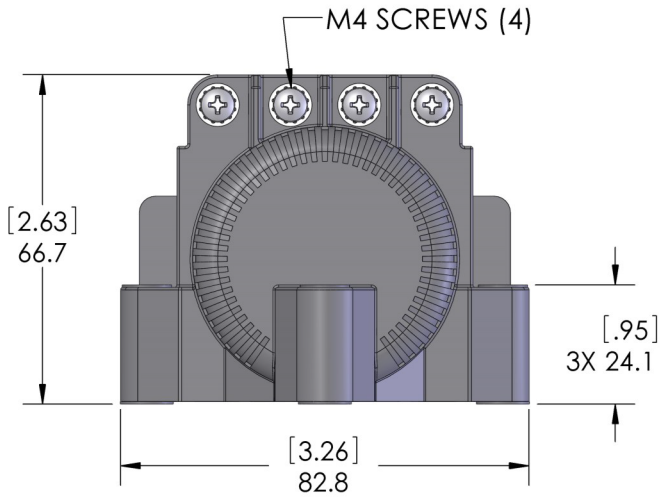

Current Carry vs Time
with 85°C terminal temperature rise

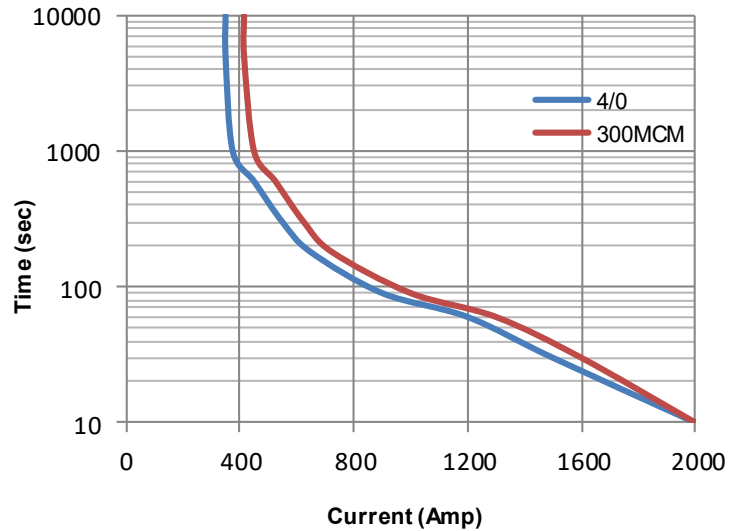

Power Terminals
Stainless M10 X 1.5 Stud
Stainless M10 X 1.5 Flanged Nut
Torque 9-10 Nm [80-90 in-lb]

Mounting Hardware
M5 [No. 10] Bolts (not incl.)
Torque 2-4 Nm [18-35 in-lb]

Case Material
25% GF Nylon 6/6, UL 94 V-O

Technical Specification	
Continuous Current	400A w/ 300MCM (see graph on reverse)
Max Current—1 sec	3000A
Max Current—10 sec	2000A
Max Current—90 sec	1000A
Contact Voltage Drop (max)	150mV at 400A
Insulation Resistance (min)	100MΩ (50MΩ after life)
Dielectric Withstanding	1500VRMS (1050 VRMS after life)
Operate Time (max)	20 msec (include bounce)
Release Time (max)	12 msec
Weight	1.1 lb with hardware (500 grams)

MX34 _ D _

Coil Voltage: _____

B = 12V
C = 24V
F = 48V

Auxiliary Contacts: _____

Blank = none
B = SPST, Normally Open

Resistive Load Switching	
400A at 24 VDC	100,000 cycles
Mechanical Life	300,000 cycles
Fault Interrupt @ 28VDC	3000A

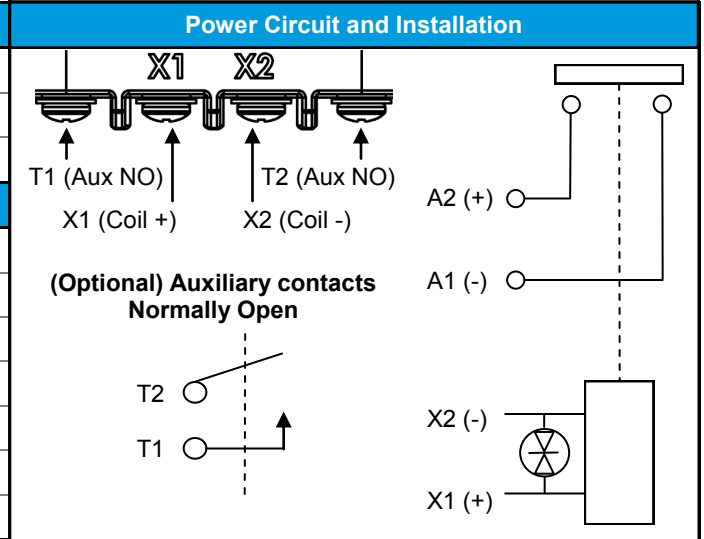

Environmental Specifications	
Seal	Hermetic, 10 E-9 atm cc/sec
Temperature Range	-55°C to +100°C
Shock	Sawtooth @ 20G, 11ms, ½ Sine @ 25G, 11ms
Vibration	10-2000 Hz, 20G
Water / Steam	2750 psi waterjet, 105 psi steam, boiling water
Salt Spray Corrosion	MIL-STD-810G
Resistant to corrosion, chemicals, and fungal growth	

Auxiliary contacts (optional) - Form A, SPST Normally Open	
Switching Current (max)	1A at 28VDC
Switching Current (min)	0.1mA at 5V

Coil Ratings at 25°C
 *Contact factory for additional coil voltages

Coil P/N Designation	B	C	F
Coil Voltage, Nominal	12 VDC	24 VDC	48 VDC
Coil Voltage, Max	16 VDC	32 VDC	64 VDC
Pick-Up Voltage, Max	8 VDC	16 VDC	40 VDC
Drop-Out Voltage	0.5 to 4 VDC	2 to 7.5 VDC	4 to 15 VDC
Pick-Up Current, Max (75ms)	3.9 A	1.6 A	0.97 A
Coil Current	0.23 A	0.097 A	0.042 A
Coil Power	2.8 W	2.3 W	2 W
Internal Coil Suppression	Transorb		
Coil Back EMF	55 V		125 V
Transients, Max (13ms)	±50 V		±75 V
Reverse Polarity	16 V	32 V	64 V



Options and Accessories	

GIGAVAC®

P.O. Box 4428
 Santa Barbara, CA 93140

www.gigavac.com info@gigavac.com **+805-684-8401**

Rev 7 27/Jan/22 © 2013 GIGAVAC, LLC Page 2 of 2 **MX34**

Datasheets provided by Sensata Technologies, Inc., its subsidiaries and/or affiliates (“Sensata”) are solely intended to assist third parties (“Buyers”) who are developing systems that incorporate Sensata products (also referred to herein as “components”). Buyer understands and agrees that Buyer remains responsible for using its independent analysis, valuation, and judgment in designing Buyer’s systems and products. Sensata datasheets have been created using standard laboratory conditions and engineering practices. Sensata has not conducted any testing other than that specifically described in the published documentation for a particular datasheet. Sensata may make corrections, enhancements, improvements, and other changes to its datasheets or components without notice.

Buyers are authorized to use Sensata datasheets with the Sensata component(s) identified in each particular datasheet. HOWEVER, NO OTHER LICENSE, EXPRESS OR IMPLIED, BY ESTOPPEL OR OTHERWISE TO ANY OTHER SENSATA INTELLECTUAL PROPERTY RIGHT, AND NO LICENSE TO ANY THIRD PARTY TECHNOLOGY OR INTELLECTUAL PROPERTY RIGHT, IS GRANTED HEREIN. SENSATA DATASHEETS ARE PROVIDED “AS IS”. SENSATA MAKES NO WARRANTIES OR REPRESENTATIONS WITH REGARD TO THE DATASHEETS OR USE OF THE DATASHEETS, EXPRESS, IMPLIED, OR STATUTORY, INCLUDING ACCURACY OR COMPLETENESS. SENSATA DISCLAIMS ANY WARRANTY OF TITLE AND ANY IMPLIED WARRANTIES OF MERCHANTABILITY, FITNESS FOR A PARTICULAR PURPOSE, QUIET ENJOYMENT, QUIET POSSESSION, AND NON-INFRINGEMENT OF ANY THIRD PARTY INTELLECTUAL PROPERTY RIGHTS WITH REGARD TO SENSATA DATASHEETS OR USE THEREOF.

All products are sold subject to Sensata’s terms and conditions of sale supplied at www.sensata.com. SENSATA ASSUMES NO LIABILITY FOR APPLICATIONS ASSISTANCE OR THE DESIGN OF BUYERS’ PRODUCTS. BUYER ACKNOWLEDGES AND AGREES THAT IT IS SOLELY RESPONSIBLE FOR COMPLIANCE WITH ALL LEGAL, REGULATORY, AND SAFETY-RELATED REQUIREMENTS CONCERNING ITS PRODUCTS, AND ANY USE OF SENSATA COMPONENTS IN ITS APPLICATIONS, NOTWITHSTANDING ANY APPLICATIONS-RELATED INFORMATION OR SUPPORT THAT MAY BE PROVIDED BY SENSATA.

Mailing Address: Sensata Technologies, Inc., 529 Pleasant Street, Attleboro, MA 02703, USA

CONTACT US

Regional head offices:

United States of America

Sensata Technologies

Attleboro, MA

Phone: 508-236-3800

E-mail: support@sensata.com

Netherlands

Sensata Technologies Holland B.V.

Hengelo

Phone: +31 74 357 8000

E-mail: support@sensata.com

China

Sensata Technologies China Co., Ltd.

Shanghai

Phone: +8621 2306 1500

E-mail: support@sensata.com

Copyright © 2023 Sensata Technologies, Inc.