

FEATURES

- > Tungsten contacts improve hot load switching
- > Contact GIGAVAC Applications Support for load capability
- > Can be mounted in any position, any axis
- > PCB and panel mount versions



PRODUCT SPECIFICATIONS

Contact & Relay Ratings	Units	G81
Contact Form		B
Contact Arrangement		SPST-NC
Voltage, Test Max., Contacts & to Base (15 µA Leakage Max., dc or 60Hz)	kV Peak	11
Voltage, Operating Max., Contacts & to Base (15 µA Leakage Max.) - dc or 60 Hz	kV Peak	10
Current, Continuous Carry Max - dc or 60 Hz	Amps	5, 10 ^{*(1)}
Resistance, Contact Max @ 1A, 28 Vdc	ohms	0.03
Operate Time	ms	10
Release Time	ms	10
Life, Mechanical	cycles	2 million
Weight, Nominal	g (oz)	56 (2 oz)
Vibration, Operating, Sine (55-500 Hz Peak)	G's	10
Shock, Operating, 1/2 Sine 11ms (Peak)	G's	30
Temperature Ambient Operating	°C	-55 to +85

* Consult factory for load switching applications.

COIL RATINGS

Nominal, Volts dc	12	26.5	115
Pick-up, Volts dc, Max.	8	16	80
Drop-Out, Volts dc	.5 - 5	1 - 10	5 - 50
Coil Resistance (Ohms ±10%)	70	290	4700

Ratings listed are for 25°C, sea level conditions

PART NUMBER SYSTEM

G81B	3	3	5
Coil Voltage	2 = 12 Vdc, PC Pins 3 = 26.5 Vdc, PC Pins 5 = 115 Vdc, PC Pins A = 12 Vdc, Panel Mount B = 26.5 Vdc, Panel Mount C = 115 Vdc, Panel Mount		
High Voltage Connections		A(2) = PCB Pins - 10 Amp 3 = PCB Pins - 5 Amp 4 = Flying Leads 5 = Stud Terminals	
Mounting			5 = PC Board 7 = Panel Mount

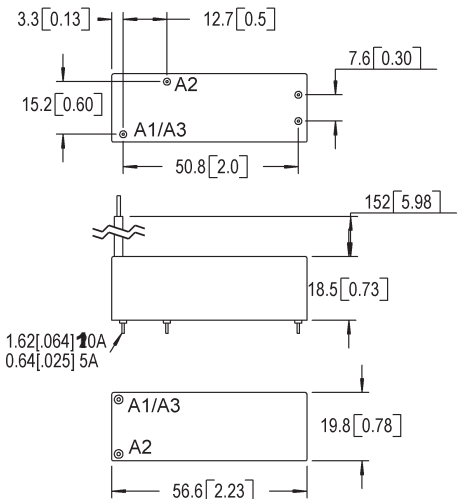
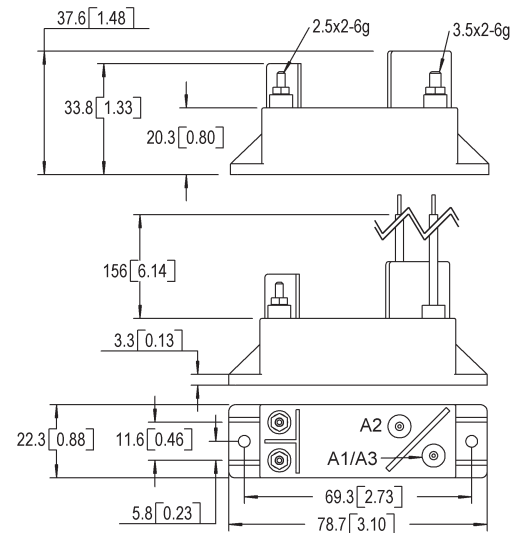

(1) PC pin versions carry 5 or 10 amps, see part number system. Flying lead and panel versions carry 10 amps.

(2) PCB Power terminals diameters:
A version, 10 amp, = 1.62mm
3 version, 5 amp = 0.64mm

Datasheets provided by Sensata Technologies, Inc., its subsidiaries and/or affiliates (“Sensata”) are solely intended to assist third parties (“Buyers”) who are developing systems that incorporate Sensata products (also referred to herein as “components”). Buyer understands and agrees that Buyer remains responsible for using its independent analysis, valuation, and judgment in designing Buyer’s systems and products. Sensata datasheets have been created using standard laboratory conditions and engineering practices. Sensata has not conducted any testing other than that specifically described in the published documentation for a particular datasheet. Sensata may make corrections, enhancements, improvements, and other changes to its datasheets or components without notice.

Buyers are authorized to use Sensata datasheets with the Sensata component(s) identified in each particular datasheet. HOWEVER, NO OTHER LICENSE, EXPRESS OR IMPLIED, BY ESTOPPEL OR OTHERWISE TO ANY OTHER SENSATA INTELLECTUAL PROPERTY RIGHT, AND NO LICENSE TO ANY THIRD PARTY TECHNOLOGY OR INTELLECTUAL PROPERTY RIGHT, IS GRANTED HEREIN. SENSATA DATASHEETS ARE PROVIDED “AS IS”. SENSATA MAKES NO WARRANTIES OR REPRESENTATIONS WITH REGARD TO THE DATASHEETS OR USE OF THE DATASHEETS, EXPRESS, IMPLIED, OR STATUTORY, INCLUDING ACCURACY OR COMPLETENESS. SENSATA DISCLAIMS ANY WARRANTY OF TITLE AND ANY IMPLIED WARRANTIES OF MERCHANTABILITY, FITNESS FOR A PARTICULAR PURPOSE, QUIET ENJOYMENT, QUIET POSSESSION, AND NON-INFRINGEMENT OF ANY THIRD PARTY INTELLECTUAL PROPERTY RIGHTS WITH REGARD TO SENSATA DATASHEETS OR USE THEREOF.

All products are sold subject to Sensata’s terms and conditions of sale supplied at www.sensata.com. SENSATA ASSUMES NO LIABILITY FOR APPLICATIONS ASSISTANCE OR THE DESIGN OF BUYERS’ PRODUCTS. BUYER ACKNOWLEDGES AND AGREES THAT IT IS SOLELY RESPONSIBLE FOR COMPLIANCE WITH ALL LEGAL, REGULATORY, AND SAFETY-RELATED REQUIREMENTS CONCERNING ITS PRODUCTS, AND ANY USE OF SENSATA COMPONENTS IN ITS APPLICATIONS, NOTWITHSTANDING ANY APPLICATIONS-RELATED INFORMATION OR SUPPORT THAT MAY BE PROVIDED BY SENSATA.

Mailing Address: Sensata Technologies, Inc., 529 Pleasant Street, Attleboro, MA 02703, USA

CONTACT US

Regional head offices:

United States of America

Sensata Technologies

Attleboro, MA

Phone: 508-236-3800

E-mail: support@sensata.com

Netherlands

Sensata Technologies Holland B.V.

Hengelo

Phone: +31 74 357 8000

E-mail: support@sensata.com

China

Sensata Technologies China Co., Ltd.

Shanghai

Phone: +8621 2306 1500

E-mail: support@sensata.com

Copyright © 2023 Sensata Technologies, Inc.

Mouser Electronics

Authorized Distributor

Click to View Pricing, Inventory, Delivery & Lifecycle Information:

Sensata:

[G81BC57](#) [G81B2A5](#) [G81BA47](#) [G81B245](#) [G81BC47](#) [G81BA57](#) [G81B-029](#) [G81B3A5](#) [G81B545](#) [G81BB57](#)
[G81B535](#) [G81B5A5](#) [G81B235](#) [G81B335](#) [G81B345](#) [G81BB47](#)